

DRG.NO

EF225M-2-B3

FRAME

EF225M-2

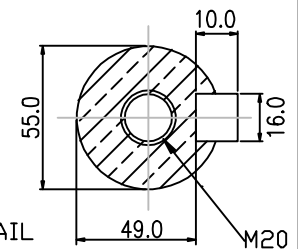
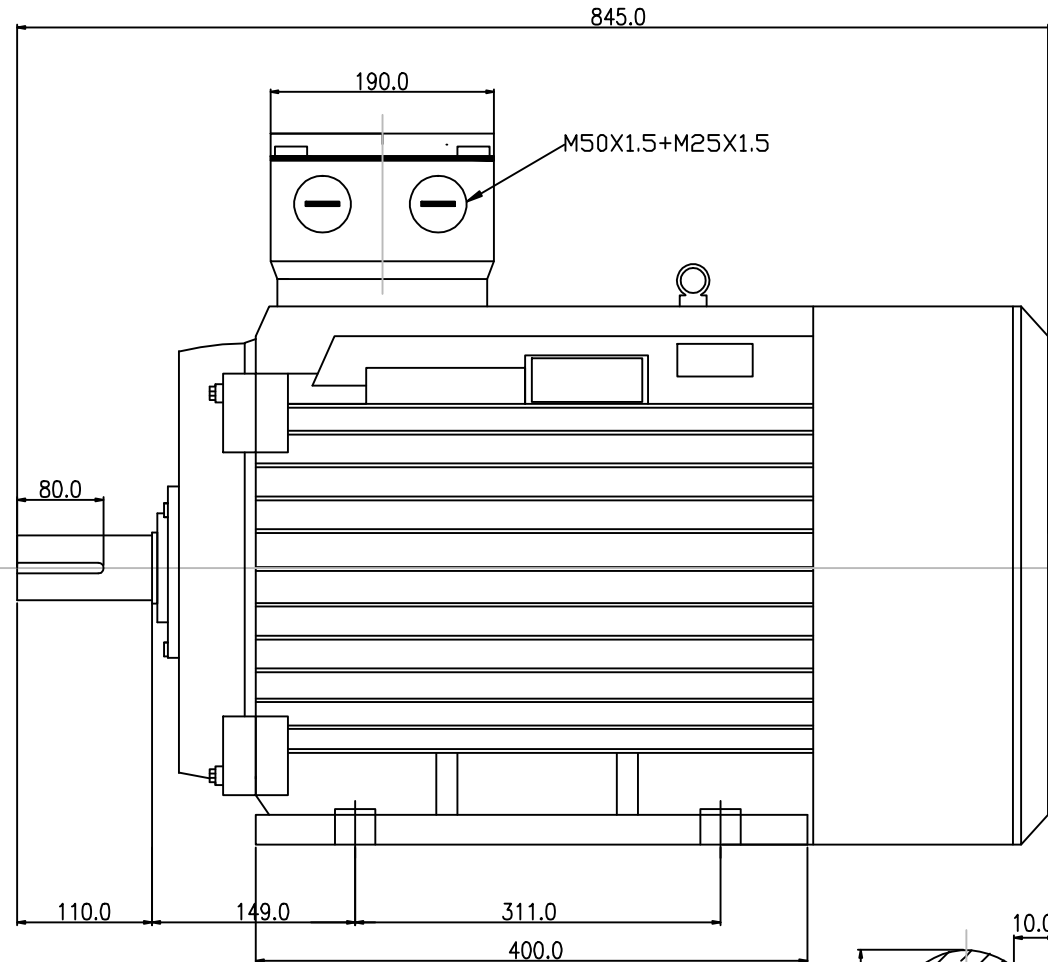
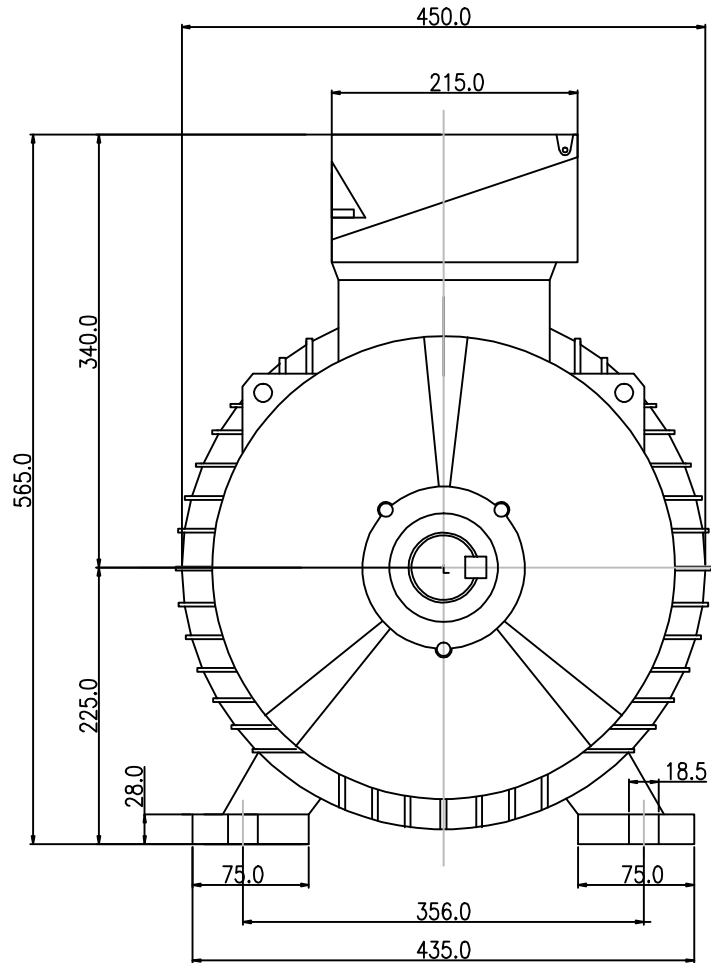

SHAFT DETAIL



3 CORD STREET
DUDLEY PARK SA 5008
Ph: (08) 8269 4000
Fax: (08) 8269 4000
www.roycecross.com.au



DRAFTING
STANDARD
AS 1100

SIZE
A4

ALL DIMENSIONS ARE IN mm
UNLESS OTHERWISE SPECIFIED
TOL. 1 PLACE DECIMAL ± 0.25 ANGLE $\pm 0.30^\circ$
2 PLACE DECIMAL ± 0.13

MATL

SPEC

TITLE

THREE PHASE INDUCTION MOTORS-TOP TERMINAL BOX
(FOOT MOUNT B3 EF225M-2)

DRN

NL

DATE

4.12.08

CHK

APPD

SCALE

NTS

DESCRIPTIONS

SHAFT TYPE EF225-2

BRAND



DRG NO

EF225M-2-B3

REV

CODE No.