

4-SLOTS SPACED AS SHOWN REF. DETAIL 'A'

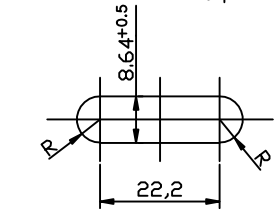

DETAIL AT 'A' SCALE 1:1

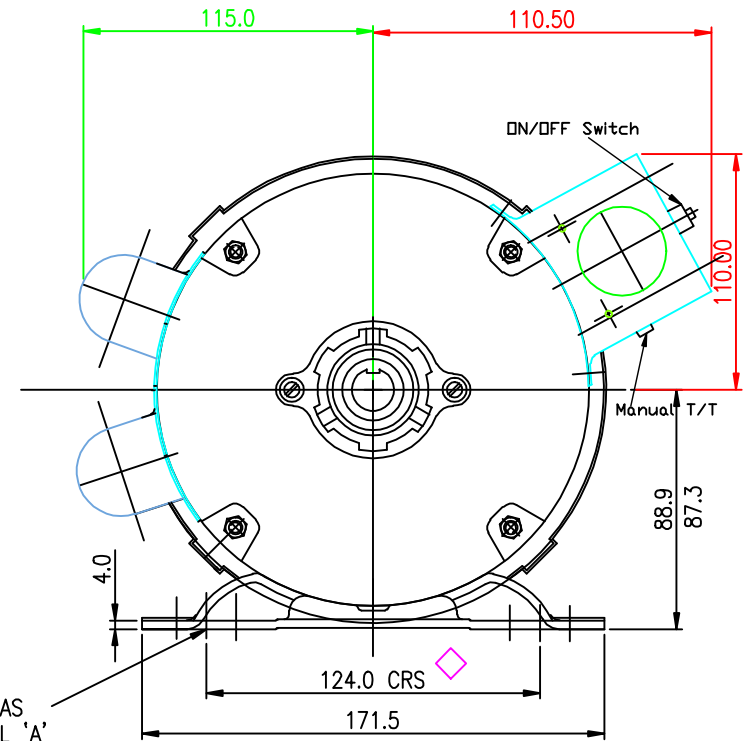

3 CORD STREET
DUDLEY PARK SA 5008
Ph: (08) 8269 4000
Fax: (08) 8269 4000
www.roycecross.com.au



DRAFTING STANDARD AS 1100

SIZE A3

TITLE

TEFC FOOT MOUNTED MOTOR
MODEL GF 7610

USED ON

RCA - BRICKSAW MOTOR

BRAND



ALL DIMENSIONS ARE IN mm UNLESS OTHERWISE SPECIFIED
TOL. 1 PLACE DECIMAL ± 0.25 ANGLE ± 0.30°
2 PLACE DECIMAL ± 0.13

DRN	NL	DATE	15.05.09
CHK		APPD	
SCALE	NTS		

KW	1.7	HP	2.25
PART NO	S1.7B2BS	AMPS	9.5
TYPE	B 56		
CAP RUN	30	CAP START	200

DRG NO	S1.7B2BS	REV	
CODE No.			