

EX 'e'

# INCREASED SAFETY MOTORS

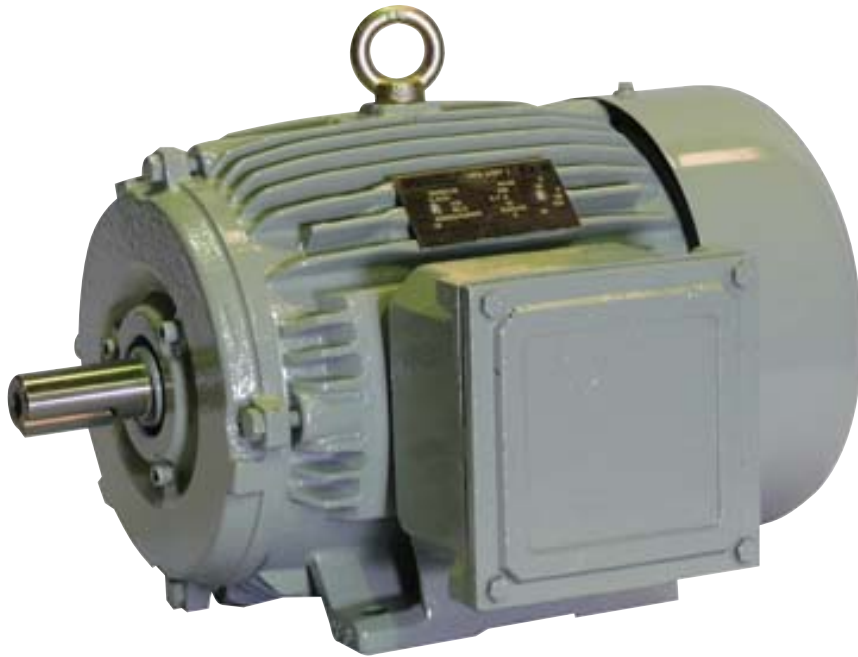

 **Crompton  
Greaves**  
EVERYDAY SOLUTIONS



## EX e INCREASED SAFETY MOTORS

Introducing the new range of MEPS 2 Compliant Crompton Greaves EX e electric motors.

All the new range EX e motors have been exhaustively tested to comply with IECEx Quality system requirements.

### Features:

EX e, IIA, IIB, T3 - Robust cast iron construction - Standard position right hand terminal box - IP55 protection - MEPS2 Compliant - IECEx Certificate 90 -315 frames.

### Performance data

kW	Frame	Pole	FL Rpm	FL Amps	Eff % FL	Net Wt Kg
----	-------	------	--------	---------	----------	-----------

2 Pole						
2.2	ND90L	2	2830	4.40	85.6	25
3	ND100L	2	2865	5.53	86.7	32
4	ND112M	2	2875	7.2	87.5	36

4 Pole						
0.55	ND90S	4	1410	1.25	78	17
0.75	ND90S	4	1410	1.70	82.5	17
1.5	ND90L	4	1415	3.00	85	25
2.2	ND100L	4	1440	4.30	86.4	32
3	ND100L	4	1445	6.15	87.4	32
4	ND112M	4	1445	7.20	88.30	42
5.5	ND132S	4	1450	10.60	89.2	68
7.5	ND132M	4	1455	13.80	90.1	79
11	ND160M	4	1460	21.00	91	125

6 Pole						
0.75	ND90S	6	935	2.00	74.6	22
1.1	ND90L	6	935	2.75	77.3	25
1.5	ND100L	6	935	3.60	79.6	32
2.2	ND112M	6	935	5.00	82.2	42
3	ND132S	6	950	8.00	85.1	68
4	ND132M	6	950	11.30	86.8	79

## EX e INCREASED SAFETY MOTORS

### Dimensional data

#### OUTLINE DIMENSION DRAWING FOR 3 PHASE SQUIRREL CAGE TEFC FOOT MOUNTED EXe/EXn INDUCTION MOTORS

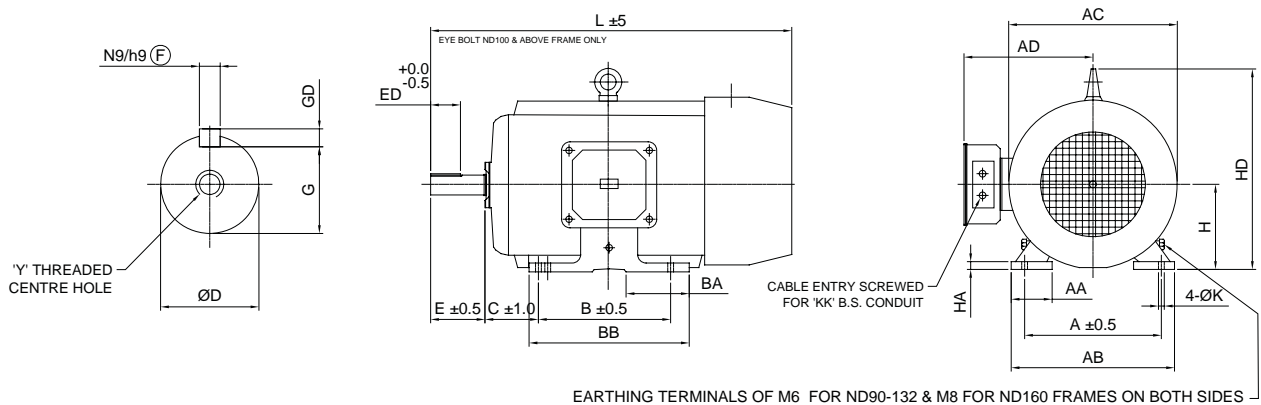

ALL DIMENSIONS ARE IN mm

FRAME SIZE	FOOT FIXING								SHAFT AND KEY						OVERALL							
	A	B	C	H TOL.	AA	AB	BA	BB	K TOL.	D TOL.	E	ED	F TOL.	GD TOL.	G	Y	AD	AC	L	HD	HA	KK
ND 90S	140	100	56	90.0	35	168	40	127	10.5	24.009	50	36	8.000	7.00	20.0	M8x19	185	195	315	-	13	M20x1.5
ND 90L		125		89.5				152											10.0			
ND 100L	160	140	63	100.0 99.5	36	192	45	170	12.5	28.018	60	44	8.000	7.00	24.0	M10x22	195	215	380	250	13	M20x1.5
			112.0 111.5	36	222	50	12.0		28.002	7.964									6.91			
ND 112M	190	140	70	112.0 111.5	36	222	50	178	12.5	38.018	80	60	10.00	8.00	33.0	M12x26	230	275	470	320	16	M25x1.5
			132.0 131.5	48	254	54	12.0												38.002			
ND 132S	216	140	89	132.0	48	254	54	178	12.5	38.018	80	60	10.00	8.00	33.0	M12x26	230	275	470	320	16	M25x1.5
ND 132M		178		131.5				215											12.0			
ND 160M	254	210	108	160.0	73	308	76	254	15.5	42.018	110	80	12.00	8.00	37.0	M16x35	275	318	605	376	22	M32x1.5
ND 160L		254		159.5				298											15.0			

### Specifications:

**Brand:** CROMPTON GREAVES STANDARD L.T. INCREASED SAFETY MOTORS.

**Construction:** CAST IRON, TEFC, TERMINAL BOX ON RIGHT HAND SIDE.

**Certified:** IECE<sub>x</sub> CERTIFIED, MEPS/EFF1, EEx e, IIA, IIB, T3, ISO9001-2000, MEPS 2 COMPLIANT.

**Insulation:** CLASS 'F' INSULATION WITH CLASS 'B' TEMPERATURE RISE.

**Voltage:** 415V, 3PHASE 50HZ AC SUPPLY.



**ROYCE  
CROSS**  
Australia

**AVAILABLE FROM**

Royce Cross Agencies

Phone: (08) 8269 4000

Fax: (08) 8269 6699

Email: [sales@roycecross.com.au](mailto:sales@roycecross.com.au)

Web: [roycecross.com.au](http://roycecross.com.au)

Address: 3 Cord Street, Dudley Park, 5008,  
South Australia